

991A Overhead Air Ionizer Installation, Operation and Maintenance



Made in the
United States of America



Figure 1. SCS 991A Overhead Air Ionizer

Description

The SCS 991A Overhead Air Ionizer is designed for use with sensitive electronic components where electrostatic discharge (ESD) is a problem. The 991A Overhead Air Ionizer provides fast static charge decay efficiency over an entire worksurface area. Equipped with task lighting, an ionization indicator light, and an integrated heater, it offers user-friendly operation while helping protect even the most sensitive components from ESD damage. The SCS 991A Overhead Ionizer easily meets the ANSI/ESD S20.20 required limits for ionization use in electronics manufacturing areas tested per ANSI/ESD STM3.1 and ESD TR53.

- Rapidly neutralizes static charges
- Covers an extended area with ionized air
- Inherently balanced to 6V
- Integrated heater and task lights
- Ionization indicator light
- AC technology for stable performance
- Built-in emitter cleaner for easy maintenance

The 991A Overhead Air Ionizer produces an air flow that is rich in positive and negative ions. Directing the air flow on an object that has a static electricity charge will neutralize the charge. If the object has a positive static charge, it will draw negative ions from the air flow. If the object has a negative static charge, it will draw positive ions from the air flow. The ions are attracted to the oppositely charged object and will neutralize the electrostatic charge on the object.

The 991A Overhead Air Ionizer features both inherent self-balance technology and a built-in emitter point cleaner. The 991A Overhead Air Ionizer operates on AC technology to provide stable balance performance over long periods of use. The 991A Overhead Air Ionizer provides fast charge decay directly under the unit for targeted worksurface coverage. The 991A Overhead Air Ionizer requires very little maintenance to ensure electrostatic charge is controlled within the worksurface area.

The 991A Overhead Air Ionizer and its accessories are available as the following item numbers:

Item	Description
991A	Overhead Air Ionizer, North America Power Cord, 120VAC
991A-E	Overhead Air Ionizer, Europe Power Cord, 230VAC
991A-U	Overhead Air Ionizer, UK Power Cord, 230VAC
991A-F	Air Filter, Pack of 6
991A AIR FILTER	Air Filter Retainer
991A LIGHT	Replacement Light Bulb

Installation

Carefully remove the equipment from the carton and inspect contents. Empty the carton to insure that small parts are not discarded.

The 991A Overhead Air Ionizer should be located 18 to 30 inches above the worksurface with center fan directly above the critical area. There should be no crossflow of air between unit and the worksurface. Drafts from air conditioning and heating air outlets can affect ionization performance.

The 991A Overhead Air Ionizer may be mounted using adjustable mounting brackets or “S” hooks provided. The mounting brackets are designed for use on a variety of surfaces such as: perforated steel angle, metal framing, and on wire shelving (see diagrams on next page).

Place a lock washer and flat washer on the lock knobs and secure the unit using center holes on mounting tab. Be sure to install a fiber washer as shown in the diagrams. The “S” hooks provide for chain mounting or mounting on wire shelving. Install the overhead ionizer unit as shown below using outer holes on mounting tabs. Chain and additional mounting hardware (not supplied) must have a minimum safe working load rating of 20 pounds.

NOTE: Prior to installing the 991A Overhead Air Ionizer, the compact fluorescent bulbs must be installed. The bulbs are placed inside the packaging material to prevent breakage during shipment. Remove both (2" x 11") lamp access panels on rear of unit with a ¼" nut driver or flat blade screwdriver. Unpack the bulbs and install by inserting the bulb into the socket and press until it “clicks” into place. Replace the lamp access panels.

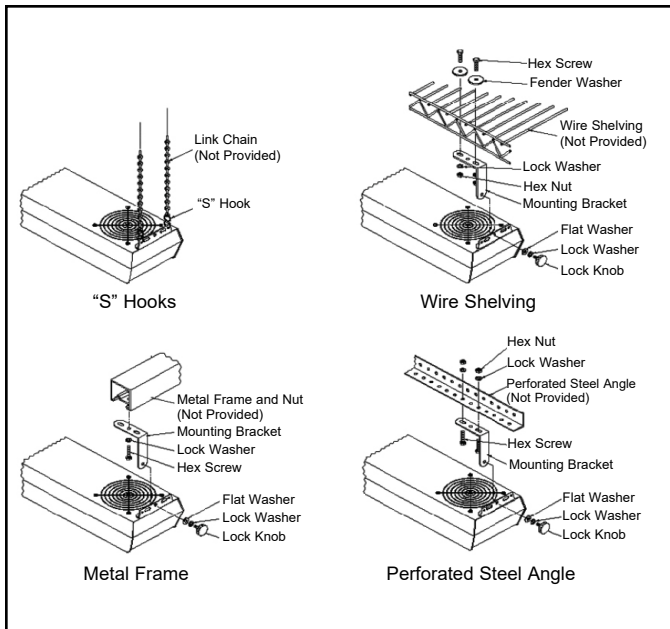

Figure 2. Mounting the 991A Overhead Air Ionizer

With the SCS 991A Overhead Air Ionizer mounted in place over the intended worksurface, plug the male end of the IEC power cord into a properly grounded 120-240 VAC 50/60 Hz receptacle. If an extension cord is necessary, use only a 3 wire properly grounded one that matches the plug type that comes with the blower.

Operation

Activate the 991A Overhead Air Ionizer by turning FAN SPEED knob clockwise, out of the OFF position. The IONIZATION INDICATOR will illuminate to indicate the presence of ionized air. Set air flow as desired by rotating the FAN SPEED knob. If warm air is desired for operator comfort, set WARM AIR switch to the ON (I) position. If light is desired, turn on task lights by setting LIGHTS switch to the ON (I) position. To clean ion emitter points, rotate the POINT CLEANER knob at each air outlet clockwise to the OFF position (approximately one turn) and release.

The time required to neutralize a static charge on an item in the air stream depends on fan speed. Setting a higher fan speed reduces time required to neutralize a static charge.

When using the SCS 991A Overhead Air Ionizer unit in an electronics assembly area, the ionized air stream should cover as much of the work area as possible. The constant flow of ionized air will help prevent items such as worksurfaces, tools, materials and components from developing a static charge. Charged items introduced into a work area will be neutralized and will remain neutral while in the ionized air stream.

Troubleshooting

This information provides a quick troubleshooting reference for the 991A Overhead Air Ionizer. Should any of these possible solutions not solve the problem, contact SCS.

Problem	Cause	Solution
Unit fails to operate	Power cord not connected	Plug in to specified voltage source
Unit fails to operate	Faulty AC ground	Replace line cord
Flashing fault light	Power incorrectly supplied to unit	Cycle power to the unit using the unit's key switch
Flashing fault light	Power incorrectly supplied to unit	Ensure that properly grounded receptacle is used
Fault light on steady	Dirty or damaged emitter tips, incorrectly calibrated	Clean tips using integrated brush
Excessively long discharge times	Dirty or damaged emitter tips, incorrectly calibrated	Clean tips using integrated brush
Excessively long discharge times	Slow fan speed or ionizer is located too far from target	Increase the fan speed or move the ionizer closer to the target
Unit fails to hold setpoint	Dirty or damaged emitter tips	Clean tips using integrated brush
Fan is slow	Fan speed is set slow	Adjust fan control clockwise

Maintenance

The SCS 991A Overhead Air Ionizer has been designed with low maintenance in mind. The only regular maintenance suggested is emitter point cleaning, ion balance checking and ion output checking. Emitter point cleaning takes only seconds. The 991A Overhead Air Ionizer contains a balancing circuit that is inherently self balancing. This circuit compensates for dirt build-up on emitters, emitter point wear, line voltage fluctuations and variations in air velocity. Scheduled checking of the ion output and balance should be considered to assure quality audit requirements.

EMITTER CLEANING

To clean the ion emitters, simply rotate the point cleaner knob located at center of each outlet clockwise to the OFF position (approximately one turn) and release. The spring-loaded point cleaning brush will return to its parking spot. Recommended frequency of cleaning is once a week.

AIR INLET AND OUTLET CLEANING

The air inlet grill on the top of the unit and the ionized air outlets should remain clean to prevent restriction of air flow. They can be cleaned with a soft brush or vacuum. Clean the air inlet grill and ionized air outlets once every three months or more often if needed. Remove the air filter element from the top of the unit by unsnapping the filter retainer. Rinse the filter in plain water while gently squeezing. If the dirt is stubborn, wash the filter in mild soap and water then rinse. Blot the filter dry with paper towels and allow to dry. Reinstall filter on air inlet and secure by snapping the filter retainer in place.

AIR FILTER CLEANING

Remove the air filter element from the top of the unit by unsnapping the filter retainer. Rinse the filter in plain water while gently squeezing. If the dirt is stubborn, wash the filter in mild soap and water then rinse. Blot the filter dry with paper towels and allow to dry. Reinstall filter on air inlet and secure by snapping the filter retainer in place.

NOTE: If an air filter is used, clean the air filter once every three months or more frequently if needed.

TASK LIGHT REPLACEMENT

If either task light does not light, dims appreciably, or flickers, the compact fluorescent lamp should be replaced as soon as possible. The 991A Overhead Ionizer uses two 13W twin tube compact fluorescent light bulbs. Access to the light bulbs are provided by a removable panel on the rear of the unit. Disconnect the power cord. Remove the appropriate lamp access panel with a 1/4" nut driver and remove the faulty light bulb. Install a new light bulb, replace the lamp access panel, and re-connect the ionizer's power cord to an appropriate electrical receptacle.

ION BALANCE VERIFICATION

To test the unit for ion balance, the use of a charge plate monitor such as the SCS [770004](#) / [770005](#) Charge Plate Analyzer is recommended.

Calibration

The SCS 991A Overhead Air Ionizer ion output is inherently balanced by design, so there are no calibration adjustments. Never open the case of the unit. This exposes the operator to hazardous voltages. If repairs are necessary, contact [SCS Customer Service](#).

Specifications

Input Voltage	120VAC, 60 Hz, 0.5A (fan low, heater/light off); 2.5A (fan high, heater/light on) 230VAC, 50 Hz, 0.2A (fan low, heater/light off); 1.5A (fan high, heater/light on)
Neutralization (Discharge) Time at 18"	≤3 seconds
Balance (Offset Voltage) at 18"	±5V
Ion Emission	AC Ionization
Coverage	2' x 4'
Cleanroom Class	Meets ISO 14644-1 Class 5; Fed std. 209E Class 100
Emitter Points	Stainless Steel
Controls	Fan speed control knob BLOWER ON; on/off switch HEATER & TASK LIGHT
Indicator Lights	Orange IONIZATION STATUS; orange within on/off switches HEATER & TASK LIGHT
Air Volume	150-300 CFM; combined 3-fan output
Heated Air Temp	25°F (14°C) fan low; 11°F (6°C) fan high measured @ 6" in front of center fan above ambient
Audible Noise	50 dBA fan low; 60 dBA fan high
Operating Env.	32 to 122°F (0 to 50°C) 30 to 70% RH, non-condensing
Ozone	0.02 ppm
Lamp	13W twin tube, compact fluorescent, 1650 lumen total task light output
Air Filter	30 ppi open cell polyurethane foam
Mounting	Adjustable brackets and S-hooks provided
Enclosure	Powder-coated white enamel aluminum
Weight	16 lbs. (7.3 kg)
Dimensions	42.75" W x 4" H x 6.75" D (108.6 x 10.2 x 17.1 cm)
Certifications	cULus, CE, RoHS
Country of Origin	United States of America

Limited Warranty, Warranty Exclusions, Limit of Liability and RMA Request Instructions

See the SCS Warranty -

<http://staticcontrol.descoindustries.com/Limited-Warranty.aspx>